

106 E. Daniel, Champaign



KEY FEATURES

- Off Street Parking Available
- Secure Building
- TV
- Dishwasher
- Hardwood Floors
- In-unit Laundry
- Newly Remodeled

- Multi-level
- 24-Hour Maintenance
- Furnished
- Fiber internet
- Wireless internet

4 bedroom

First Floor

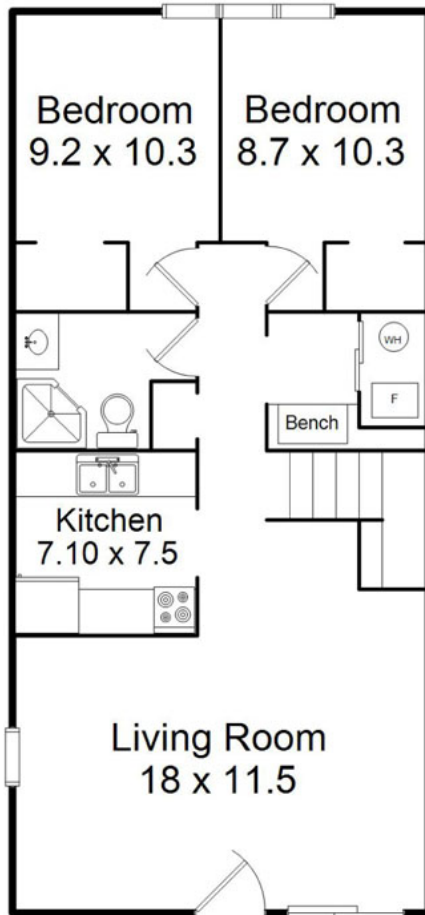

Second Floor

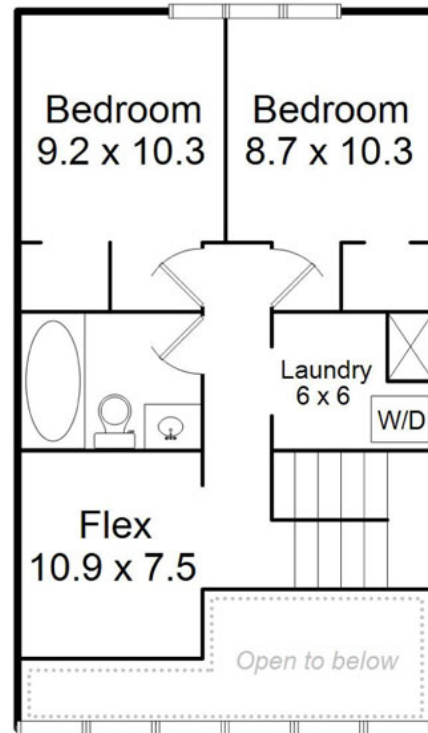

Price per month : \$0.00

Price per occupant : \$0.00

Bathrooms : 2

Comments :

Top floor, townhouse layout with amazing natural light. 100% newly renovated!

2 bedroom

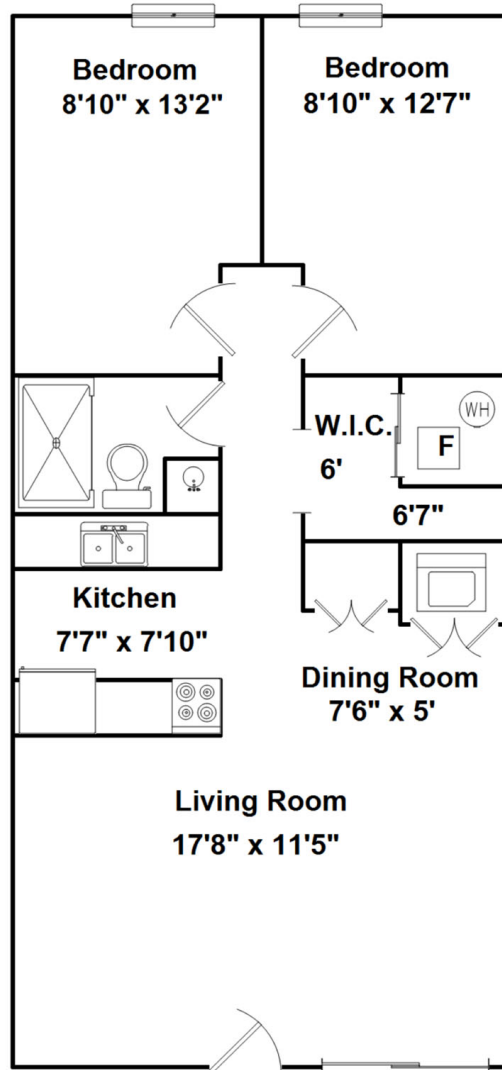

Price per month : \$1530.00

Price per occupant : \$765.00

Bathrooms : 1

Comments :

Fully-renovated with stainless steel appliances, quartz counter tops, plank flooring, includes washer/dryer in-unit, TV, and desks.

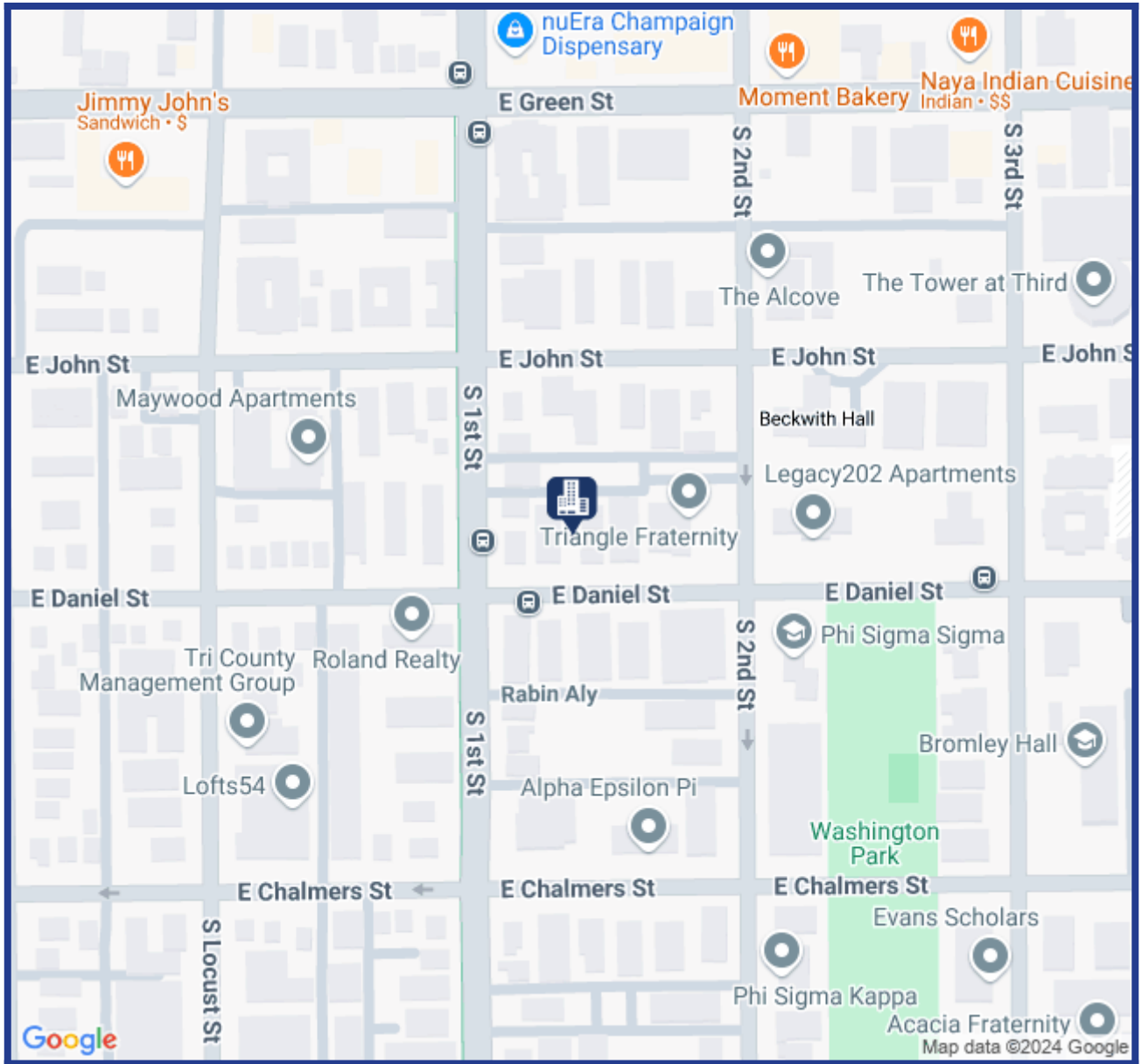

Copyright 2024 © The University Group